

EMO valve drive

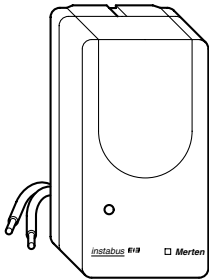

Colour **Article no.**
 polar white 639119

Table of Contents

1.	Function	1
2.	Installation	1
3.	Technical Data	2
4.	Settings in the EIB Tool Software (ETS)	2
5.	Application overview	2

1. Function

Electromotive valve drives are used in room temperature control e.g. on heaters, radiators, convectors, heat distributors for underfloor heating systems, ceiling cooling systems, ceiling radiant heating systems as well as blowers and induction devices in two- or four-wire systems. The device is suitable for installation on thermostatic valve bodies. During the commissioning or after bus voltage recovery, the lift position of the valve is determined via an adjustment routine of the valve drive by moving to the limit positions (closed and fully open). The valve lift (4.5 mm) can be controlled in 255 positions via an 8 bit control value. The motor switches off as soon as the required position (control value) is reached. The position is retained without motor power due to the self-locking gearing. The positioning force is adapted in the closing range to thermostatic valve bodies with soft valve discs. The adjustment routine is run automatically after approx. 4000 received setpoint values or readjustments of the drive and after each interruption of the bus voltage. The current position and the status of the valve drive can be sent via the bus.

2. Installation

The electromotive, proportional EMO valve drive is connected directly to the INSTABUS; a separate bus coupler is not required. An external auxiliary voltage is not necessary. It should be noted that a valve motor draws as much energy from the bus as two bus devices. The enabling of the programming of the physical address is carried out without contact using the programming magnet (art. no. 639190) or another magnet. A red programming LED is used as a status display.

The maintenance-free drive operates at low noise. The compact plastic housing accommodates the motor, gearing, lift detection and the bus coupler. The valve drive can be mounted on all Heimeier thermostatic valve bodies. The bus connection is carried out via the 1 metre long connecting cable which is fixed to the device with the help of a bus connecting terminal (art. no. 689701).

Device view:

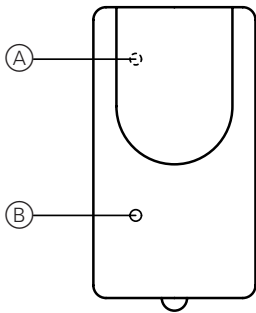

- (A) Activation point for programming magnet
- (B) Programming LED

3. Technical Data

Nominal voltage:	DC 24 V (+6 V / -4 V)
Leakage loss:	240 mW (same capacity as approx. 2 bus devices)
Power consumption:	approx. 12 mA
Lift:	max. 4.5 mm
Running time:	25 s/mm
Type of protection:	IP 44 in accordance with EN 60529 (vertical, upright installation)
Protection class:	III in accordance with EN 60730
Housing, colour:	Plastic, white in accordance with RAL 9010
Connection	
Connecting cable:	1 m fixed; J-Y (St) Y 1x2x0.6 mm
On the bus:	via bus connecting terminal
Temperature	
Operation:	0 °C to +50 °C
Storage:	-20 °C to +70 °C
Medium:	max. 100 °C
Installation:	Suitable for all Heimeier thermostat valve bodies. Adapters for valve bodies of other manufacturers are available from Heimeier
Operating elements:	Magnet-sensitive sensor for the assignment of the physical address
Display elements:	Red LED for checking the programming and display of a drive error
Dimensions:	88x47x61 mm (HxWxD)

Connection example

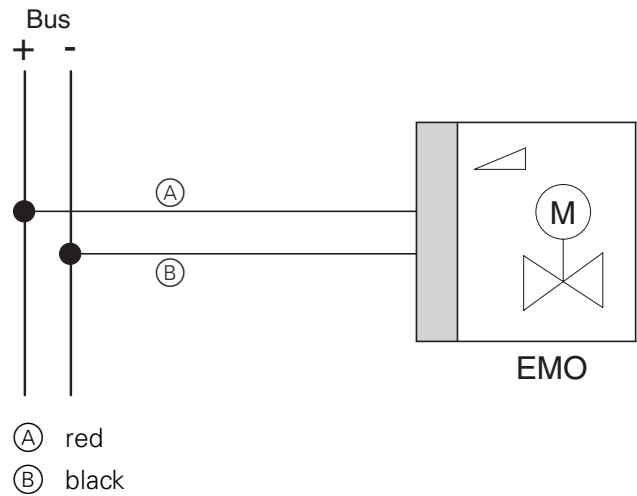

4. Settings in the EIB Tool Software (ETS)

Selection in the product database

Manufacturer:	Merten
Product family:	7.1 Heating/Single room thermostat
Product type:	7.1.12 Valve drive
Program name:	8 bit digits 4213/4
Media type:	Twisted Pair
Product name:	EMO valve drive
Order number:	639119

5. Application overview

The following application is available:

Application	Vers.	Function
8 bit digits 4213/4	4	Valve lift of the valve drive can be set in 255 positions (8 bit)
		Cyclical communication possible with the room temperature control unit
		Fault signal of the valve drive
		Priority control of the drive via a 1 bit telegram (window contact)
		Set the control action of the valve drive (break/make contact)

Communication objects

The valve drive has four different communication objects.

However, it is not necessary to link all objects to group addresses. Connecting object 0 with output object "Control value for heating" (frequently object 7) for the continuous controller suffices for easy heating control. Objects 1 to 3 are intended for advanced functionality, for example, the evaluation of window contacts or for reading out the actual value.

Object 0 is used as an input for normal regulating processes. The 8 bit value is assigned proportionally to the measured "true" valve lift. This object is normally linked to the output "Control value for heating" (or cooling) for the room temperature control unit (frequently object 7).

Object 1 is used as an output for the current position of the valve. If the valve is idle, the contents of object 1 and object 0 are identical. During the regulating process, object 0 is the setpoint and object 1 is the actual value. It is recommended that object 1 be linked to a group address mainly in combination with visualisation software.

Object 2 comprises of the status code of the valve after the occurrence of a fatal error. It shows the value 0 if everything is OK. Any other values indicate an error.

00	Everything OK
01	Retrigger error (e.g. expiry of the cyclic monitoring period)
FF / 255	Error during adjustment

Object 3 is used as an input for forced positioning. Two options (0 and 1) arise for the 1 bit value. If a 0 is sent to this object by the bus, then the device uses the value of object 0 as the current setpoint (this is the normal behaviour).

If the value 1 is sent to object 3, then the device adopts a configurable forced position. Should object 0 receive a value from the bus after this, then this value will be ignored because, in this case, object 3 has priority over object 0. The valve can, therefore, be controlled via an 8 bit object (object 0) or a 1 bit object (object 3). If KNX-capable window contacts are located on the windows, then their group addresses can be linked to object 3 of the valve drives.

The following functionality is produced in the process:

If the windows are closed, the telegrams from the room temperature control unit determine the valves' degree of opening. If one or more windows are open, the drives adjust themselves to the configurable forced position. The room temperature control unit will increase the control value as a result of the lowered temperature, but cannot enforce this, since the drive ignores these telegrams (priority of object 3 over object 0). If the windows are closed again (a 0 is sent to object 3), the control value sent by the room temperature control unit is applied and the following values are implemented normally again.

It is recommend, however, that normally the window contacts be connected up via the room temperature control unit (i.e. connecting the group addresses for the window contacts to the object "Frost protection" of the controller), since it is only this that can influence the actual room temperature. If the valve drive is moved into its forced position, no statement can be made about the actual room temperature due to the wide variety of conditions prevailing for the heating system.

The use of object 3 is recommended when only one room temperature control unit is installed in a larger room, but several valve drives are installed with some windows equipped with window contacts. In which case, namely, a forced position approach can be realised for every valve drive separately (depending on the opening status of the windows).

Description of the parameters

Preset values are printed in **bold**

General parameters for the valve drive can be set here.

Parameters:	Possible values:	Description:
Direction of control	<ul style="list-style-type: none"> • Normal: 0% (closed).....100% (open) • Inverted: 0% (opened)...100 % (closed) 	Allocation of the control value to the valve position, i.e. possible inversion of the direction of control
Checking of cyclic time	<ul style="list-style-type: none"> • YES • NO 	Enablement of the monitoring period, which controls the receiving of the cyclic control value from a temperature control unit.
Cyclic monitoring period <i>(only visible when "Check cyclic time") is activated</i>	<ul style="list-style-type: none"> • 33 s – 45 min. (Standard: 16 min.) 	Adjustment of the monitoring period to the cyclic sending time of the temperature controller. (Should always be selected longer than the monitoring period of the controller)
Control value after initialisation or if no controller is present	<ul style="list-style-type: none"> • 0% .100% in 10% steps (standard: 50%) 	Setting the active control value that is approached after an adjustment routine or after the set monitoring period has expired.
Start of self-calibration dependent on the number of	<ul style="list-style-type: none"> • received control value - telegrams • actual adjustments 	The valve drive starts a readjustment after a certain number of counted events. Determined here is which event causes the counter to be increased until the next adjustment.
Control value for priority object	<ul style="list-style-type: none"> • 0%...100% in 10% steps (Standard: 20%) 	Specification of the control value that is moved to the priority object, object 3, after a "1" has been received. A change is only useful if object 3 is linked to a window contact, for example.
Flashing of the programming LED in event of drive or valve error	<ul style="list-style-type: none"> • ON • OFF 	Clarification whether an error status is to be displayed by the prog. LED flashing

Send status in event of error	<ul style="list-style-type: none">• ON• OFF	Clarification whether a status telegram is to be sent in the event of an error
Valve type*	<ul style="list-style-type: none">• Thermostatic valve• optimised for HEIMEIER standard up to 1/2"• Valve with linear characteristic curve• user-defined valve (reserved for future valve types)	Selection of the valve to be controlled



Notes on setting the valve type

Thermostatic valve (factory setting)

This setting is the standard setting and covers the majority of valves on the market.

optimised for HEIMEIER standard up to 1/2"

This setting may only be selected if it can be ensured that HEIMEIER standard valves have really been installed. Otherwise, correct closing of the valves cannot be guaranteed. (This setting should be selected if HEIMEIER standard valves up to a size of 1/2" are used in the heating system.

For more detailed information, please contact the manufacturer.

Valves with linear characteristic curve

This setting must be used for valves with a linear flow characteristic curve.

Correction of errors / Answers to frequently asked questions

If an error occurs during the adjustment or normal operation, then the adjustment routine is subsequently started several times. If, after several attempts, the adjustment is still unsuccessful, this will be evaluated as an error.

Errors are treated as follows:

1. The LED built into the device starts to flash when applicable (dependent on the configuration). This error status can either be deleted by a reset (reset command on bus or power disconnection) or by pressing the programming button (magnet). Prior to the LED flashing, the drive attempts fully start up (frost protection).
2. After the error status has been deleted, the adjustment routine is restarted.
3. Depending on the configuration, an error telegram can be issued on the bus.

If the valve drive flashes, please note the following questions first:

Why is the valve drive flashing?

If the valve drive is flashing, please make sure that the drive is screwed onto a valve, since adjusting without a valve will result in a drive error. This is a safety function for preventing unnecessary actuations. After installation on a valve, the flashing should disappear.

If the drive is flashing despite installation on a valve, there is probably a mismatch between valve and drive. Please note down the manufacturer and type of the installed valve exactly and install, if necessary, the suitable adapter. A list containing the suitable adapters for the majority of valves on the market is available below for your perusal. If you have any more queries, please consult our customer service department.

Why is the room too warm?

If a room is overheated, firstly make sure that the "*Flashing of the programming LED in event of drive or valve error*" option is switched on. This enables clear error allocation. If the drive is flashing, please observe the information in the appropriate chapter.

If the drive is not flashing in an overheated room, this could also involve, in certain circumstances, a mismatch between valve and drive. If the closing extent of the valve used is too deep, it is possible that the drive cannot completely close the valve when the tappet is fully extended (lower mechanical stop), which results in a heat generating flow still being present. The use of the appropriate adapter helps here.

A non-adjusted room temperature control unit could also be the reason for a room being too warm. This can be checked by comparing the actual temperature on the controller (read out of the group address linked to the corresponding object of the room temperature control unit inside the ETS2) and the temperature on an external, if possible, precision thermometer. On the product database disk there is additional software in the "RTRAbgl" subdirectory which simplifies this (without starting the ETS2). If the actual temperatures do not match up, then a temperature offset has to be programmed subsequently in the ETS2 for the relevant controllers. Please contact the manufacturer of the relevant room temperature control unit for more detailed information on the procedure.

Another reason for the room being too warm, which can also be the case when HEIMEIER thermostatic valves are being used, is the presence of dirt particles in the heating system, causing the sealing for the thermostatic valves to not close correctly. If necessary, contact your heating installation company to check the heating system.

Why is the room too cold?

If the room is too cold, a malfunction in the drive is improbable, since the drive starts a readjustment when an error is detected and only comes to a stop fully opened after several unsuccessful attempts and flashes, if necessary. (Please set the "*Flashing of the programming LED in event of drive or valve error*" to "ON"). Thus, in the event of a malfunction, it is more likely the room would be overheated. A more likely explanation as to why the room is too cold would be due to an unfavourable location or if adjustment of the room temperature control unit has not taken place. First, check the setpoint temperature and the actual temperature on the room temperature control unit by reading out the matching group addresses and compare these, where applicable, with a *precision* thermometer installed in the centre of the room. On the product database disk there is additional software in the "RTRAbg!" subdirectory which simplifies this (without starting the ETS2). Adjust the controller if the temperature on the thermometer and the actual temperature on the controller are too varied. If you have any queries on this, please contact the manufacturer of the temperature control unit. Please observe also the correct installation for the room temperature control unit. Correct operation is almost impossible if the device is installed in the proximity of sources of heat or in areas subjected to draughts.

To eliminate the possibility of drive error, you can specify a control value to the drive by sending a value (e.g. "255" - fully opened) to the group address linked to object 0 of the drive. The heating should get warmer after a certain period of time. (Please note that the heating is a delay-action system in which changes therein can take quite some time).

Tip: Disconnect the relevant room temperature control unit from the bus coupler since the controller, in certain circumstances, will overwrite the control value sent by you (cyclical sending from the room temperature control unit).

For which valves is the valve drive compatible?

The valve drive is compatible with all HEIMEIER thermostatic valve lower sections, and, by means of adapters, is also compatible with a multitude of valves from other manufacturers. We cannot guarantee these are fault-free, however, due to unforeseeable technical modifications by the valve manufacturers. If you have any more queries or are not clear about something, please consult our customer service department. You could also take the opportunity to ask about the latest adaptation options.