

**Room temperature control unit for properties**

**System M**

Operating instructions

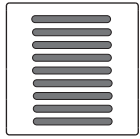

Art. no. MEG6221-03../MEG6221-04..

**For your safety**



**DANGER**

**Risk of fatal injury from electrical current.**

The device may only be installed and connected by skilled electricians. Observe the regulations valid in the country of use, as well as the valid KNX guidelines.

**Getting to know the controller**

The room temperature control unit for properties (referred to below as the **controller**) is designed for different types of property (school, hospital, public building, etc.). All settings relevant to room temperature control can only be parameterised using the KNX Tool Software (ETS). The controller has neither display nor operating elements so that it is protected against misuse by unauthorised persons.

**Functions of the room temperature control unit:**

- Heating / cooling with one controller output
- Heating / cooling with separate controller outputs
- Heating / cooling with two controller outputs
- Heating / cooling (2 levels) with four control outputs

The controller is directly connected to the KNX and parameterised by the electrician using the ETS.

**Scope of delivery**

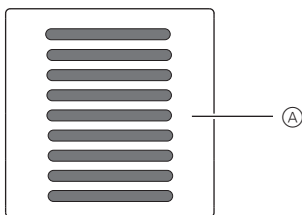

Ⓐ controller

**Connections, displays and operating elements**

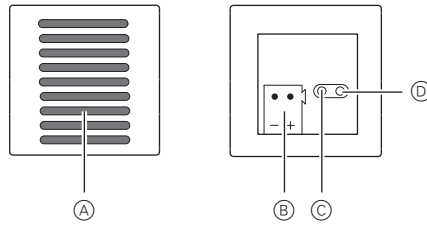

Front:

Ⓐ Openings for thermostat

Back:

- Ⓑ Bus connection
- Ⓒ Programming button
- Ⓓ Programming LED

**Installation side**

You must take the following points into consideration when selecting the installation location for the room temperature control unit in order for it to work optimally::

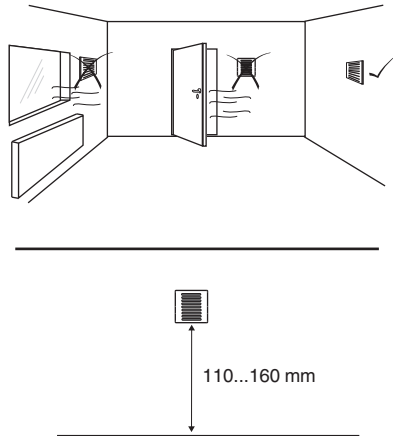

**Sources of interferences**

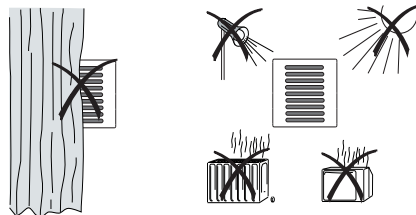

**Mounting the controller**

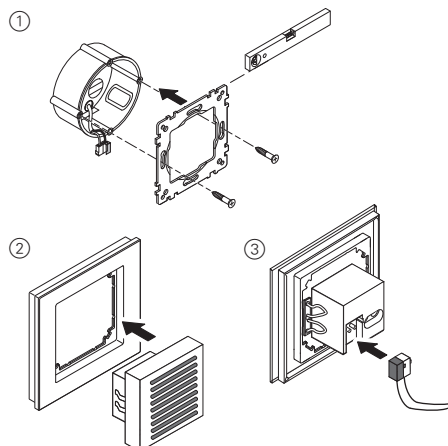

**Operating the controller**

- ① Set the controller to the programming state.

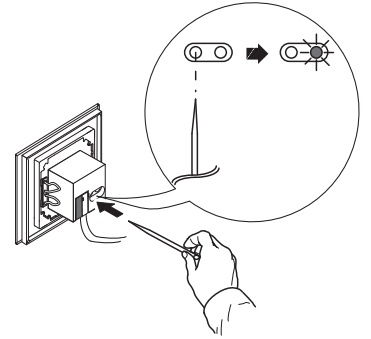

- ② Load the physical address and application from the ETS into the controller. The red programming LED goes out.

- ③

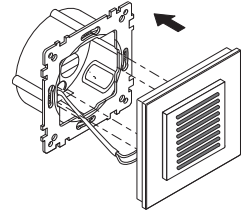

**Technical data**

Power supply:	via KNX
Connection:	Bus terminal connection
Measurement range:	0 to 40 °C
Measurement accuracy:	± 1 K, depends on installation location
Controller type:	2-point controller continuous PI controller switching PI controller (PWM)
Controller mode:	Heating with 1 controller output Cooling with 1 controller output Heating and cooling with separated controller outputs 2-stage heating with 2 controller outputs 2-stage cooling with 2 controller outputs 2-stage heating and 2-stage cooling with 4 controller outputs
Protection type:	IP 20

**Merten GmbH**

Merten GmbH, Solutions for intelligent buildings, Service Center, Fritz-Kotz-Str. 8, Industriegebiet Bomrig-West, D-51674 Wiehl

Phone: +49 2261 702-204

Fax: +49 2261 702-136

E-Mail: [servicecenter@merten.de](mailto:servicecenter@merten.de)

Internet: [www.merten.com](http://www.merten.com)

**If you have technical questions, please contact our InfoLine:**

Phone: +49 1805 212581\* or +49 800 63783640

Telefax: +49 1805 212582\* or +49 800 63783630

E-Mail: [infoline@merten.de](mailto:infoline@merten.de)

\*fee required

## Settings in ETS

### Selection in the product database

Manufacturer:	Merten
Product family:	7.1 Heating/Single Room Thermostat
Product type:	7.1.17 System M thermostat
Range name:	Object RTR 1819/1.0
Media type:	Twisted Pair
Product name:	Room temperature control unit for properties
Order number:	MEG6221-03xx, MEG6221-04xx

 The application can only be operated with ETS3.

### Application overview

Application	Vers.	Functions
Object RTR 1819/1.0	1	Signal function
		Room temperature control unit
		Behaviour when bus voltage recovers/ bus voltage fails

## Application object RTR 1819/1.0

### Function overview

This application gives you the room temperature control unit and a signal function.

The controller is mainly used in places where you want to make sure it is not tampered with, e.g. by visitors. The controller therefore has no push-button operation and no control menu.

### Group addresses

Group addresses are managed dynamically. Maximum number of group addresses and assignments: 254 addresses, 255 connections

### Notes on this documentation

This application enables you to implement a multitude of functions. However, which functions are possible in each individual case depends on the KNX devices being controlled (e.g. dimming actuators, switch actuators etc.). The functions described here therefore show only the settings for this device.

 Many parameters and their settings are dependent on the settings you have already made for other parameters. This means that some parameters will appear or disappear and the values available for selection will change according to settings you have already made. These dependencies have not been shown in the table for reasons of clarity. All settings are always shown.

 Configurable times (staircase timer, ON delay, OFF delay, cyclic intervals etc.) are set via the base and factor parameters. The actual time is given by the multiplication of the two values. Example:  
 Base = 1 second \* factor = 3 gives 3 seconds.

 The **bold** values in a table are the values set during factory configuration.

### Basic settings

Before you begin, set the start-up delay for the device in the "General" tab.

The start-up delay is the time delay between the bus voltage recovery and the device's functional start. Set a time after which the current values can be read by other KNX devices.

General	
Parameter	Settings
Device's start-up delay in s (0-255)	<b>2-255, 4</b>

Use signal function

### Use signal function

The signal function enables the device to display whether the actual temperature is above or below a pre-set value.

When a signal is issued, a "1" is transmitted to the bus via the "Signal object output", and a "0" is transmitted after the signal is finished.

 The signal cannot be acknowledged.

Signal function	
Parameter	Settings
Use signal function	Yes <b>No</b>
Report if actual temperature is higher than	20,0 = 68.0 °F to 40.0 °C = 104.0 °F, <b>No</b>
Report if actual temperature is lower than	0,0 = 32,0 °F to 19,0 °C = 166.2 °F, <b>No</b>

### Communication objects

You can select the following communication objects:

Function	Object name	Type	Prio	Flags	Behaviour
Signal function	Feedback object output	1 bit	Low	CT	Transmit

### Getting to know and parameterising the room temperature control unit

As for all parameters, the recommended settings are already specified here. However, you must check all parameters to make sure that they are set correctly and appropriately for your installation's local conditions.

Control general	
Parameter	Settings
Use control	<b>Yes</b> No

### How the room temperature controller functions

There are many factors that can affect room temperature. The task of the control is to detect the actual temperature constantly, and to ensure that the heating or cooling system receives new information accordingly. The heating or cooling system converts this information and adjusts the room temperature to the preconfigured setpoints.

The actual temperature is constantly measured by the temperature sensor integrated into the controller. However, you can also measure the temperature via an external sensor and transfer it to the controller via the bus, which then takes it fully or partially into account when assessing the actual temperature.

The controller can control the connected heating/cooling systems via corresponding switch telegrams or continuous correcting variables. In this way, both PI controls and 2-step controls can be parameterised.

Four operation modes (comfort, standby, night and frost/heat protection) for which setpoints can be set in each case are available for differentiated control with different requirements.

Additional functions of the room temperature control unit are comfort extension, shared/separate correcting variable output, selection of the operation mode after reset, offset of the setpoint temperatures, 1 bit/1 byte status objects, taking into account a temperature which has been measured separately, temperature drop detection, and valve protection.

## Setpoints and operation modes

Four operation modes are available to help you control the room temperature:

- **Comfort mode**  
Controls the room temperature when the room is being used.
- **Standby mode**  
Lowers temperature slightly when the room is not being used.
- **Night operation**  
Lowers temperature significantly, e.g. at night or during the weekend.
- **Frost/heat protection**  
Automatically switches on the heating or cooling when adjustable temperature threshold values are not reached or are exceeded.

The additional "comfort extension" operating mode acts in the same way as the comfort mode, but can be exited automatically after an adjustable time period. You can switch back and forth between these operating modes using communication objects.

You can specify a setpoint for each operation mode. When changing the operation mode, the relevant setpoint for continued room temperature control is used. You can adjust the setpoints for all operation modes (except for frost/heat protection) within adjustable limits using the "Setpoint adjustment input" object. You can also specify whether setpoint adjustment affects

- The current operation mode only or
- All operation modes

## Setpoint adjustment affects current operation mode only

In this setting, the setpoint temperature of the current operation mode is changed. You can select whether or not the setpoint adjustment is retained after the operation mode is switched.

 The operation mode switch via frost/heat protection does not affect the setpoint adjustment.

### Setpoint adjustment maintained after change in operation mode = No

Comfort = 2 °C	Comfort -> Standby -> Comfort	Comfort = 0 °C
Standby = 0 °C		Standby = 0 °C
Night = 0 °C		Night = 0 °C
Comfort = 2 °C	Comfort -> Frost protection-> Comfort	Comfort = 2 °C
Standby = 0 °C	> Comfort	Standby = 0 °C
Night = 0 °C		Night = 0 °C

### Setpoint adjustment maintained after change in operation mode = Yes

Comfort = 2 °C	Comfort -> Standby -> Comfort	Comfort = 2 °C
Standby = 0 °C		Standby = 0 °C
Night = 0 °C		Night = 0 °C

The setpoint adjustment is specified directly via the "Setpoint adjustment input" object. In contrast to this, a new setpoint temperature can be set via the "Current setpoint temperature input" object. Setpoint adjustment is determined here by the difference between the current setpoint temperature and the object value.

#### Example 1

Heating, current operation mode = standby  
 Limits of setpoint adjustment = +3 K/-3 K  
 Setpoint adjustment: Object "Setpoint adjustment input" = +3 °C

Initial status	Result
Comfort = 21 °C	Comfort = 21 °C
Standby = 19 °C	Standby = <b>22 °C</b>
Night = 17 °C	Night = 17 °C
Frost protection = 7 °C	Frost protection = 7 °C

#### Example 2

Heating, current operation mode = comfort  
 Limits of setpoint adjustment = +5 K/-5 K  
 New set value: Object "Current setpoint temperature input" = +30 °C

Initial status	Result
Comfort = 21 °C	Comfort = <b>26 °C</b>
Standby = 19 °C	Standby = 19 °C
Night = 17 °C	Night = 17 °C
Frost protection = 7 °C	Frost protection = 7 °C

### Setpoint adjustment affects all operation modes

In this setting, you not only change the setpoint temperature for the current operation mode, you change all the setpoint temperatures in the same way and at the same time. The only setpoint temperatures that are not affected are those for the frost/heat protection. These operation modes also specify the limits of the setpoint adjustment. It is therefore not possible to set setpoint temperatures lower than the frost protection or higher than the heat protection.

The setpoint adjustment is specified directly via the "Setpoint adjustment input" object. In contrast to this, a new setpoint temperature can be set via the "Current setpoint temperature input" object. The setpoint adjustment is defined here by the difference between the current temperature and "Reference setpoint for the calculation of the setpoint adjustment".

#### Example 1

Cooling/heating

Limits of setpoint adjustment = +3 K/-3 K

Setpoint adjustment: Object "Setpoint adjustment input" = +5 °C

Initial status	Result
Cooling:	Cooling:
Heat protection= 35 °C	Heat protection= 35 °C
Night = 28 °C	Night = <b>31 °C</b>
Standby = 26 °C	Standby = <b>29 °C</b>
Comfort = 24 °C	Comfort = <b>27 °C</b>
Heating:	Heating:
Comfort = 21 °C	Comfort = <b>24 °C</b>
Standby = 19 °C	Standby = <b>22 °C</b>
Night = 17 °C	Night = <b>20 °C</b>
Frost protection = 7 °C	Frost protection = 7 °C

#### Example 2

Cooling/heating

Limits of setpoint adjustment = +10 K/-10 K

Setpoint adjustment: Object "Setpoint adjustment input" = +20 °C

Initial status	Result
Cooling:	Cooling:
Heat protection= 35 °C	Heat protection = 35 °C
Night = 28 °C	Night = <b>35 °C</b>
Standby = 26 °C	Standby = <b>33 °C</b>
Comfort = 24 °C	Comfort = <b>31 °C</b>
Heating:	Heating
Comfort = 21 °C	Comfort = <b>28 °C</b>
Standby = 19 °C	Standby = <b>26 °C</b>
Night = 17 °C	Night = <b>24 °C</b>
Frost protection = 7 °C	Frost protection = 7 °C

#### Example 3

Cooling/heating

Limits of setpoint adjustment = +3 K/-3 K

New set value: Object "Current setpoint temperature input" = 24 °C

Reference setpoint for calculating the setpoint adjustment = 21 °C

Calculated setpoint adjustment = +3 °C

Initial status	Result
Cooling:	Cooling:
Heat protection= 35 °C	Heat protection= 35 °C
Night = 28 °C	Night = <b>31 °C</b>
Standby = 26 °C	Standby = <b>29 °C</b>
Comfort = 24 °C	Comfort = <b>27 °C</b>
Heating:	Heating:
Comfort = 21 °C	Comfort = <b>24 °C</b>
Standby = 19 °C	Standby = <b>22 °C</b>
Night = 17 °C	Night = <b>20 °C</b>
Frost protection = 7 °C	Frost protection = 7 °C

The active operating state of the controller is determined by the states of the communication objects: "Comfort extension", "Comfort", "Night reduction", "Frost/heat protection" and "Dewpoint alarm".

The highest priority when calculating the setpoints is the dewpoint alarm. If this goes off, heating is still possible but cooling is deactivated ("0" at controller output). The dewpoint alarm is terminated when its communication object is set to "0".

After a reset, the operation mode you preconfigured is active. The corresponding setpoints then also apply. When a setpoint adjustment is received via the bus, the controller checks whether it lies within the parameterised limits, and if necessary, adjusts it to the corresponding limits.

## Comfort mode

This operation mode is used to control the room temperature when the room is being used.

The comfort mode is active when (a presence detector for example) reports a presence via the "Comfort input" object. An external push-button is also an option

When the comfort mode is terminated via the "Comfort input" object (value = 0), the standby or night operation mode is activated. This is useful as an office application for central resetting, for example.

You can set the controller to automatically switch to this state after a reset or a download.

Control general	
Parameter	Settings
Operation mode after reset	Comfort operation <b>Standby operation</b> Night operation Frost/heat protection Last operation
Operation mode after download	<b>Comfort operation</b> <b>Standby operation</b> Night operation Frost/heat protection

## Communication objects

You can select the following communication objects:

Function	Object name	Type	Prio	Flags	Behaviour
Control	Comfort input	1 bit	Low	WC	Receive
Control	Comfort output	1 bit	Low	CRT	Transmit

## Comfort extension

The comfort extension operation mode is largely the same as the comfort mode. However, the comfort extension is exited automatically after a time period that you can set. It temporarily suppresses the night operation mode when the room is used for longer during the evening, for example.

You can call up the comfort extension via the "Comfort extension" object. The parameterised time for the comfort extension runs to an end and can then be restarted, for example by activating the comfort extension again.

The comfort extension is terminated:

- When the parameterised time has elapsed.
- If you allow the comfort extension to be terminated by the objects "Comfort", "Night reduction" or "Operation mode".

You can parameterise the controller so that, once the comfort extension has ended, the controller:

- Switches to standby mode.
- Switches to night operation.
- Switches to the operation mode specified by the current value. A precondition for this is that the parameter "Termination of comfort extension via objects" is set to "No".

Control general	
Parameter	Settings
Duration of comfort extension	none Test mode (1 min) 30 min to 4.0 h, <b>1.0 h</b>
Termination of comfort extension via objects*	Yes <b>No</b> *Objects: comfort, standby, operation mode
Operation mode after comfort extension	Standby operation Night operation <b>Current object values</b>

## Communication objects

You can select the following communication objects:

Function	Object name	Type	Prio	Flags	Behaviour
Control	Comfort extension input	1 bit	Low	WC	Receive
Control	Comfort extension output	1 bit	Low	CRT	Transmit

## Standby operation

This operation mode enables you to reduce or increase the room temperature to a parameterised level as soon as the room is no longer in use. A brief heating period or cooling period is triggered by the low difference in temperature to the comfort mode.

The standby mode is activated if all the operation mode objects equal "0", i.e. the operation modes "Dewpoint alarm", "Night reduction", "Frost/heat protection" or "Comfort" are inactive.

You can set the controller to automatically switch to this state after a reset or a download.

Control general	
Parameter	Settings
Operation mode after reset	Comfort operation <b>Standby operation</b> Night operation Frost/heat protection Last operation
Operation mode after download	Comfort <b>Standby operation</b> Night operation Frost/heat protection

## Night operation

This operation mode enables you to reduce or increase the room temperature to a greater extent during the night or over the weekend. In this operating mode, you use a "1" telegram to switch via the "night economy" object.

Night operation is activated if the objects Comfort extension and Comfort are set to "0" and the object "Night reduction input" is set to "1".

Night operation ends

- When the "Night reduction input" object is set to "0", or
- When the "Comfort extension", "Comfort" or "Standby" operation mode is selected.

You can set the controller to automatically switch to this state after a reset or a download.

Control general	
Parameter	Settings
Operation mode after reset	Comfort operation <b>Standby operation</b> Night operation Frost/heat protection Last operation
Operation mode after download	Comfort operation <b>Standby operation</b> Night operation Frost/heat protection

## Frost/heat protection

The parameterised values for frost protection (e.g. +7°C) or heat protection (e.g. +35°C) are set as new setpoints with a "1" telegram to the "Frost/heat protection input" object. This prevents the room from becoming overheated or the heating from freezing. A "0" telegram terminates "Frost/heat protection" and the previous operation mode is set again. The operating mode is determined by the current information for the objects "Comfort extension input", "Comfort input" and "Night reduction input". If no change occurs, the previous operation mode is set. This does not apply when the "dew point alarm" operating mode is also active.

## Dew point alarm

The dewpoint operation mode is used to switch off the cooling in all circumstances. A "1" telegram to the "Dewpoint alarm" object switches off the cooling when there is condensation in the cooler. This operation mode has the highest priority. A "0" telegram terminates the "dewpoint alarm" and the new operation mode is set. The operation mode is determined by the current information for the objects "Comfort extension input", "Comfort input" and "Night reduction input". If no change occurs, the previous operation mode is set.

## Locking object

You can use the control's locking object to activate the frost/heat protection with priority.

Application: A push-button at the building's exit enables you to switch the system to the away setting, for example. In this case, the heating only comes on during extreme cold. If the window contacts are monitored and the windows are only closed after the away setting is activated, the frost/heat protection remains active anyway.

### Toggleing between operation modes via 1 bit

The following shows toggling between operation modes via 1 bit.

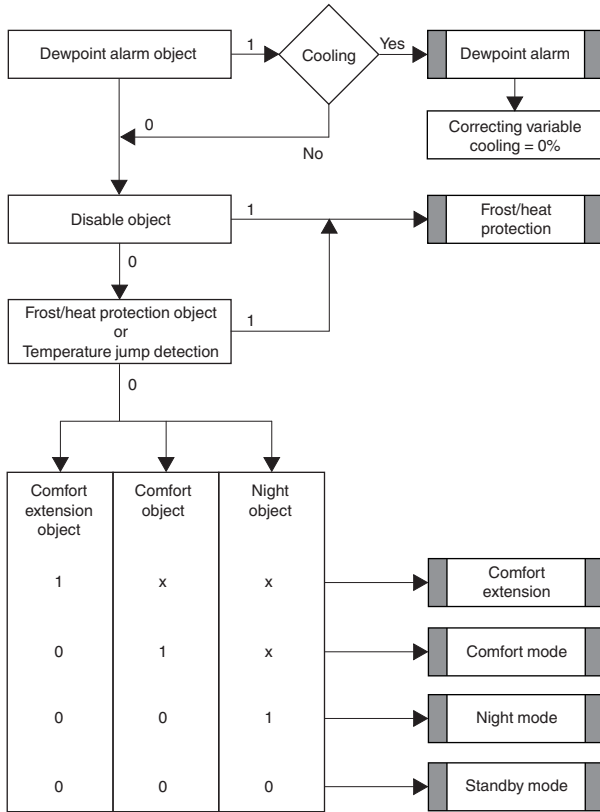

### Toggleing between operation modes via 1 byte

The following shows toggling between operation modes via 1 byte.

- "4" = frost/heat protection
- "3" = night economy
- "2" = standby
- "1" = comfort

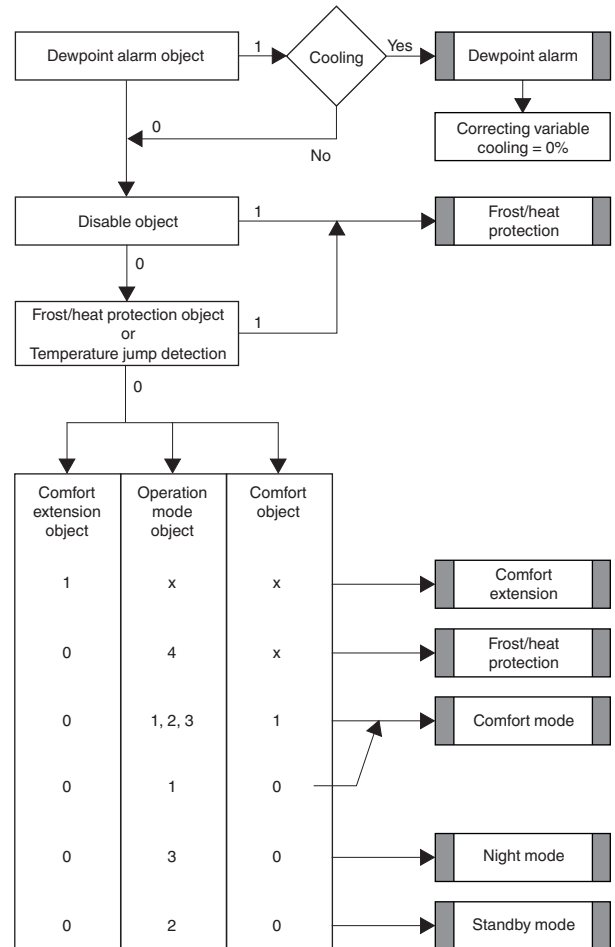

## Heating and cooling

### Heating

In the heating control mode, the current actual temperature is compared with the current setpoint temperature. If the actual temperature lies below the setpoint temperature, this control difference is counteracted by issuing a setpoint which does not equal "0".

Heating with constant correcting variables (e.g. EMO valve drive):

- Radiator/convactor warm water heating
- Underfloor warm water heating
- 2-circuit underfloor warm water heating
- Air convectors

Heating with switching correcting variables (e.g. switch actuator):

- Electric convactor
- Night storage heating
- Ceiling heating

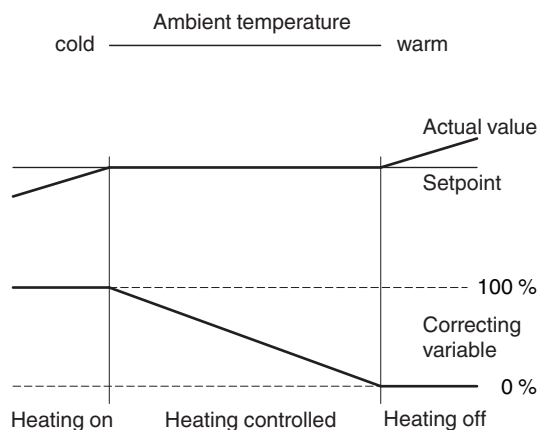

### Cooling

In the cooling control mode, the current actual temperature is compared with the current setpoint temperature. If the actual temperature lies above the setpoint temperature, this control difference is counteracted by issuing a setpoint which does not equal "0".

Cooling with constant correcting variables (e.g. EMO valve drive):

- Cooling ceiling
- Air convectors

Cooling with switching correcting variables (e.g. switch actuator):

- Cooling ceiling
- Air convectors

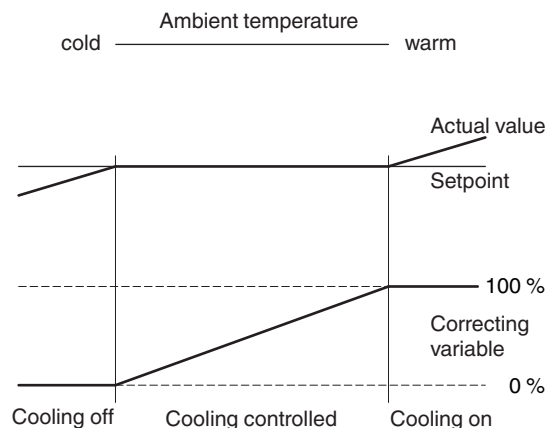

### Heating and cooling

Using the "Toggle between heating and cooling" parameter, you can set whether heating and cooling are

- Set automatically by the controller or
- Set externally via the "Heating/cooling" object.

If you have selected the "Heating/cooling" object, the controller can only be forced into heating or cooling mode by the object value.

**i** If you have set the parameter "Toggle between heating and cooling" to "External (via heating/cooling object)" then after a download or bus voltage recovery, a read request is sent to the bus by the "Heating/cooling" object.

- If the object does not receive a response after a download, the controller sets itself to "Heating" and the object sends a "1" to the bus.
- If the object does not receive any status feedback after bus voltage recovery, the controller switches to the last mode.
- If the object receives a status feedback, the object's operation mode is set.

If automatic mode was selected, the controller decides which control mode is suitable based on the parameterised setpoints, the insensitive zone and the current actual temperature.

### The insensitive zone

The insensitive zone prevents the controller from switching constantly between heating and cooling. For example, if a heater is used for heating, it has sufficient thermal energy after the valve has been closed to continue to heat the room above the setpoint temperature. If you have projected the same value for the heating and cooling setpoints, the insensitive zone is set to "0 K". The air conditioning unit cools immediately because the setpoint for cooling has been exceeded. The procedure repeats itself again and again.

Another error occurs if the heating setpoint was set higher than the cooling setpoint. The controller remains inactive until you rectify the error in the ETS and re-load the parameters.

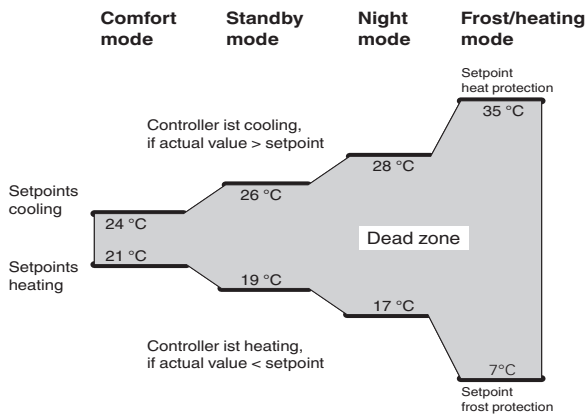

Heating and cooling with constant correcting variables (e.g. EMO valve drive):

- 2-pipe fan coil
- 4-pipe fan coil (with external switching between heating and cooling)
- 4-pipe fan coil (with automatic switching between heating and cooling)
- 1-circuit air conditioned ceiling
- Cooling ceiling with combined warm water heating
- Cooling ceiling with combined underfloor heating
- Variable air volume

Heating and cooling with switching correcting variables (e.g. switch actuator):

- Cooling ceiling
- Air convectors

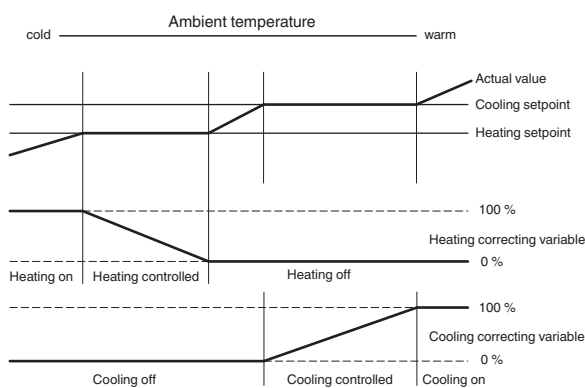

**Adjust the setpoint ranges for heating and cooling together**

**i** The difference between the two setpoints (heating and cooling) is interpreted as the insensitive zone.

For example:

The upper and lower setpoint adjustment is 3 K respectively.

Actual value = 21 °C; Heating setpoint = 22 °C; Cooling setpoint = 24 °C, this results in an insensitive zone of 2 K.

The setpoint temperature is now lowered incrementally.

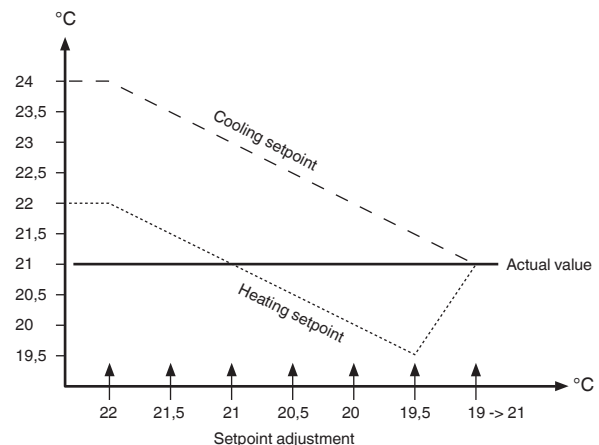

The jump from 19.5 to 21.0 can be explained by the fact that the cooling setpoint is relevant now because the actual temperature is more than or the same as the cooling setpoint temperature. Depending on the setting, this setpoint adjustment affects all the operation modes or just the current operation mode.

Setting ""Setpoint adjustment only has an effect on the current operation mode". If comfort mode is currently activated, you can adjust the comfort setpoints for heating and cooling together, but you can not adjust the values for standby or night operation.

### Two-stage heating or cooling

In order to shorten the heat-up phase with slow heating systems (e.g. underfloor heating), a second, more responsive heating system that heats up faster during the long start-up period of the main system (basic level) is frequently used.

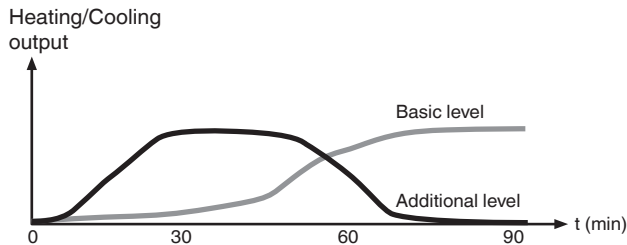

The same behaviour applies with cooling systems.

The additional level, which is controlled via 2-step control, remains switched on until a parameterised interval below the basic level is reached (e.g. 2 K), and then switches off. Only the basic level then remains switched on.

For example:

- Setpoint temperature: 21 °C
- Interval between basic level – additional level: 2 K
- Hysteresis of additional level: 1 K

The additional level remains switched on until "Setpoint temperature minus level interval" ( $21^{\circ}\text{C} - 2\text{ K} = 19^{\circ}\text{C}$ ) is reached. The additional level is then switched off.

It is only switched on again when the actual temperature is lower than the "Setpoint temperature minus interval level minus hysteresis" ( $21^{\circ}\text{C} - 2\text{ K} - 1\text{ K} = 18^{\circ}\text{C}$ ).

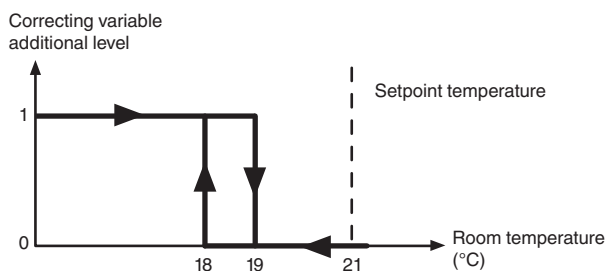

### Controller types

The room temperature control unit transmits correcting variables to the bus via various communication objects, which you can use to control different controller types with switching commands or by specifying percentage values:

- Continuous 2-step control
- Switching 2-step control
- Continuous PI control
- Switching PI control

#### Continuous and switching 2-step control

The 2-step control is the simplest type of control. The heating switches on as soon as the actual temperature falls below a specific value, and switches off as soon as the setpoint temperature has been exceeded.

#### Switching 2-step control:

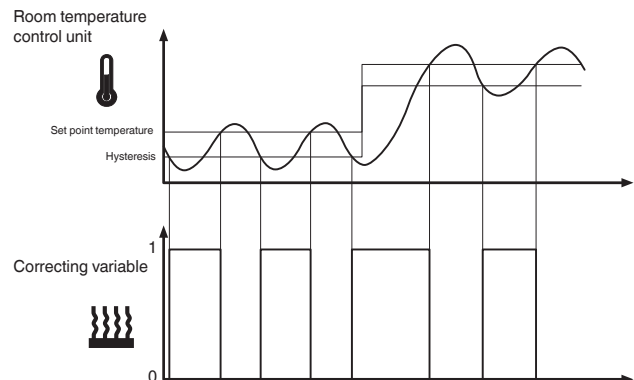

#### Continuous 2-step control:

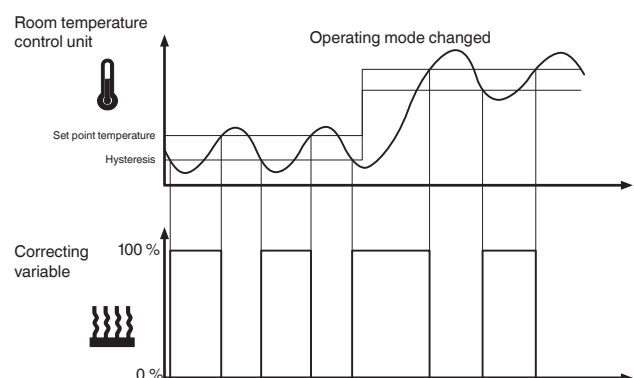

The disadvantage of simple control, in contrast to its advantage, is that the room temperature is not constant but changes continuously, reducing comfort particularly when heating and cooling systems are slow to react. To counteract this effect, you can set a sufficiently small hysteresis. However, this leads to an increase in switching frequency, and therefore to increased wear of the drives.

The temperature overshoot above or below the hysteresis

esis apparent in the diagram is caused when the heating/cooling system continues to emit heat or cold into the room after it has been switched off.

### Setting rules for the 2-step control

"Hysteresis of the 2-step control" parameter:

- Small hysteresis:  
Leads to small fluctuations, but frequent switching.
- Large hysteresis:  
Leads to large fluctuations, but infrequent switching.

**i** In general, due to the influences of the heating system and the room, the temperature fluctuations in the room are significantly higher than the hysteresis.

### Continuous and switching PI control

For the PI control, the correcting variable is calculated from a proportional and an integral share. The calculation is governed by parameters such as:

- Temperature difference between actual value and setpoint
- Proportional range
- Reset time

In this way, the controller can correct the room temperature quickly and accurately. The corresponding correcting variable is transferred via a 1 bit/1 byte value to the bus.

The standard control parameters for the most common system types are already installed in the controller:

- Warm water heating
- Underfloor heating
- Electric heating
- Fan convector
- Split unit
- Cooling ceiling

You can also set the control parameters for the proportional range and the reset time manually, but you should know exactly which actuators are connected and the control conditions in the room.

### Continuous PI control

For the continuous PI control, the corresponding 1 byte correcting variable is transmitted 0-100% directly via the bus to the heating actuator or an EMO valve drive, which convert the correcting variable directly to a degree of opening. However, this is only transmitted when the newly calculated correcting variable has changed by a specified percentage.

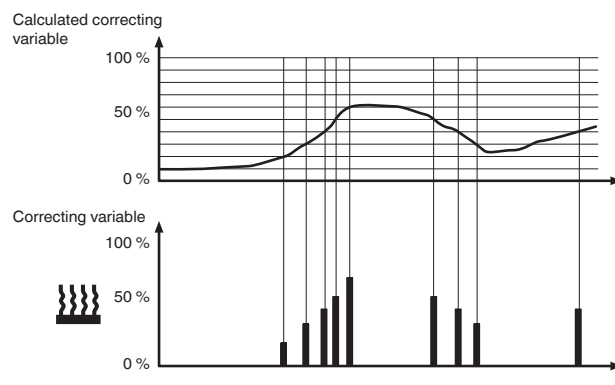

### Switching PI control (PWM)

With the switching PI control, also known as the PWM control, the correcting variables calculated by the controller (0-100%) are converted into a pulse-width modulation (PWM). Within a constant, defined cycle time, the control actuator is opened ("1") and then closed again ("0") for the calculated percentage period. For example, when a correcting variable of 25% is calculated for a cycle time of 12 minutes, a "1" is transmitted at the beginning of the cycle time, and a "0" is transmitted after three minutes (= 25% of 12 minutes).

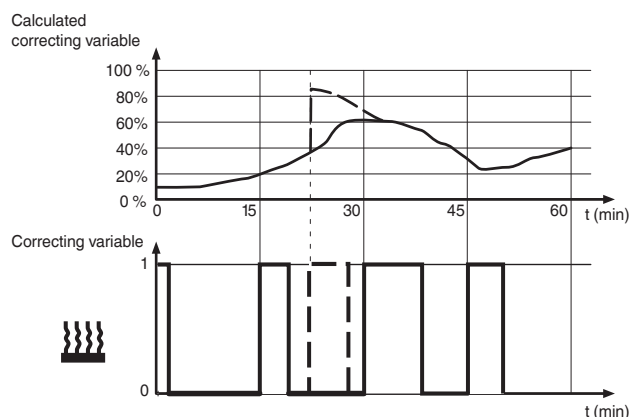

When the setpoint temperature changes, the controller recalculates the required correcting variable and transmits it still within the current cycle (broken line).

## Setting rules for the PI control

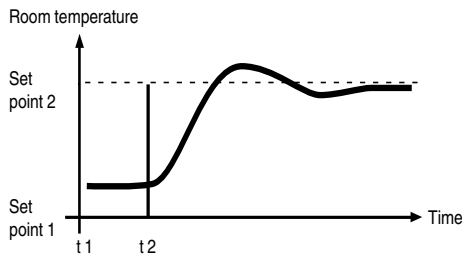

In general:

- Large system increases (e.g. high heating output, steep characteristic curves for valves) are controlled with large proportional ranges.
- Slow heating systems (e.g. underfloor heating) are controlled with high-level reset times.

If no satisfactory control result is achieved by selecting an appropriate heating or cooling system, you can improve the adaptation "via control parameters":

- Small proportional range:  
Large overshoot for setpoint changes (also continuous oscillation under certain circumstances), rapid adjustment to the setpoint.
- Large proportional range:  
No (or little) overshooting, but slow adjustment.
- Short reset time:  
Rapid correction of control deviations (ambient conditions), risk of continuous oscillation.
- Long reset time:  
Slow correction of control deviations.

The framework conditions for setting the cycle time are as follows:

- For small values, the switching frequency and the bus load are increased.
- For large values, temperature fluctuations are created in the room.
- A short cycle time for rapid heating systems (e.g. electric heating).
- A long cycle time for slow heating systems (e.g. underfloor warm water heating).

## Examples

Warm water radiator heating with motorised valve drives:

Characteristics	Parameter	Setting
Heating only	Controller type	Heating
	Correcting variable output	Continuous PI control
	Adjust the controller to the heating system	Warm water heating (5 K/150 min)

Cooling ceiling with motorised valve drives:

Characteristics	Parameter	Setting
Cooling only	Controller type	Cooling
	Correcting variable output	Continuous PI control
	Adjust the controller to the cooling system	Adjustment via control parameter
	Cooling proportional range	Approx. 5 K (depending on the application)
	Reset time for cooling	Approx. 240 min. (depending on the application)

Switching electric radiator heating:

Characteristics	Parameter	Setting
Heating only	Controller type	Heating
	Correcting variable output	Switching PI control
	Adjust the controller to the heating system	Electric heating (4 K/100 min)

Air conditioning with 4-duct (2-circuit) air convector system (e.g. switching valve drives):

Characteristics	Parameter	Setting
Heating or cooling as required, with automatic switching	Controller type	Heating and cooling
	Correcting variable output - heating	e.g. switching PI control
	Adjust the controller to the heating system	Air convector (4 K/90 min)
	Correcting variable output - cooling	e.g. switching PI control
	Adjust the controller to the cooling system	Air convector (4 K/90 min)

e.g. automatically switch between heating and cooling automatically via the controller

Temperature limitation using shading facility:

Characteristics	Parameter	Setting
Cooling only	Controller type	Cooling
	Correcting variable output - heating	Switching 2-step control
	Hysteresis	Large (e.g. 2 K)

## Setting the room temperature control unit

### Setting the general control parameters

Set the control first. Then specify which control type you want to plan.

Specify

- Whether and how the comfort extension should function, and which operation mode the device should go to after a reset.
- Whether setpoint adjustments remain the same or whether the predefined setpoint should be used again when the operation mode is changed.
- How large a setpoint adjustment is allowed.
- Whether the setpoint adjustment affects the current operation mode only or all operation modes.

Control general	
Parameter	Setting
Use control	<b>Yes</b> No
Controller type	<b>Heating</b> Cooling Heating and cooling
Duration of comfort extension	none Test mode (1 min) 30 min to 4.0 h, <b>1.0 h</b>
Termination of comfort extension via objects*	Yes <b>No</b>
*Objects: comfort, standby, operation mode	
Operation mode after comfort extension	Standby operation <b>Night operation</b> Current object values
Operation mode after reset	Comfort operation <b>Standby operation</b> Night operation Frost/heat protection operation Last operation
Operation mode after download	Comfort operation <b>Standby operation</b> Night operation Frost/heat protection operation
On what the setpoint adjustment has an effect	<b>Current operation mode</b> All operation modes
Setpoint adjustment maintained after change in operation mode	Yes <b>No</b>
Max. upper setpoint adjustment	0 - 10 K, <b>3 K</b>
Max. lower setpoint adjustment	0 - 10 K, <b>3 K</b>
Switch between heating and cooling	<b>Automatically (via the controller)</b> Externally (via heating/cooling object)
Heating/cooling read request after bus voltage recovery	Yes <b>No</b>
Waiting time after switching-over (heating/cooling)	Yes <b>No</b>
Waiting time (1-60 min)	1 ... 60, <b>10</b>

If you have parameterised the "**Heating and cooling**" controller type, either the controller automatically switches between heating and cooling or it is done by the "Heating/cooling" object accordingly.

If the controller automatically switches between heating and cooling, it is either in heating mode or cooling mode. The correcting variable of the non-active mode is switched to 0% (off).

When toggling externally, switch to the heating mode with a "1" telegram, and to cooling mode with a "0" telegram.

If the same transmitting group address is used for the heating and cooling setpoints, the "0" telegrams of the non-active controller type are automatically suppressed.

### Setting the operation mode and status

Here you can set whether to toggle between operation modes via 1 bit or 1 byte. Additionally, you define the 1 bit status object here.

If you want to display the system's status using visualisation software, there is one 1 byte status object and one 2 byte status object available for this purpose.

Operation mode/status	
Parameter	Setting
Toggle operation mode via 1 bit/1 byte	<b>1 bit</b> 1 byte
Define 1 bit status object	Bit 0: Comfort Bit 1: Standby Bit 2: Night operation <b>Bit 3: Frost/heat protection</b> Bit 4: Dewpoint alarm Bit 5: Heating (1)/cooling (0) Bit 6: Controller inactive Bit 7: Frost alarm (1)

Structure of the 1 byte status object:

- Bit 0 Comfort (1/0)
- Bit 1 Standby (1/0)
- Bit 2 Night operation (1/0)
- Bit 3 Frost/heat protection (1/0)
- Bit 4 Dewpoint alarm 1/0
- Bit 5 Heating (1)/cooling (0)
- Bit 6 Controller inactive (1/0)
- Bit 7 Frost alarm (1/0)

Getting to know and parameterising the room temperature control unit

**Structure of the 2 byte status object:**

- Bit 00 Error (1/0)
- Bit 01 \* (0)
- Bit 02 \* (0)
- Bit 03 \* (0)
- Bit 04 Additional heating level (1/0)
- Bit 05 \* (0)
- Bit 06 \* (0)
- Bit 07 Heating inactive (1/0)
- Bit 08 Heating (1)/cooling (0)
- Bit 09 \* (0)
- Bit 10 Additional cooling level (1/0)
- Bit 11 Cooling inactive (1/0)
- Bit 12 Dewpoint alarm (1/0)
- Bit 13 Frost alarm (1/0)
- Bit 14 Temperature alarm (1/0)
- Bit 15 \* (0)

\*not supported

**Setting the setpoints**

For each operation mode, there is a setpoint available for temperature control when changing operation mode automatically or manually. You have to specify this setpoint. There is no setpoint adjustment for frost or heat protection.

**Reference value for calculating the setpoint adjustment:**

This parameter is only activated if the setpoint adjustment is to affect all operation modes equally ("Control general" tab). If you set a new setpoint temperature using the "Current setpoint temperature input" object, the setpoint adjustment is calculated from the difference between the reference value and the object value.

**Example**

Cooling/heating  
 Limits of setpoint adjustment = +3 K/-3 K  
 New set value: Object "Current setpoint temperature input" = 24 °C  
 Reference setpoint for calculating the setpoint adjustment = 21 °C  
 Calculated setpoint adjustment = +3 °C

Initial status	Result
Cooling:	Cooling:
Heat protection= 35 °C	Heat protection= 35 °C
Night = 28 °C	Night = <b>31 °C</b>
Standby = 26 °C	Standby = <b>29 °C</b>
Comfort = 24 °C	Comfort = <b>27 °C</b>
Heating:	Heating:
Comfort = 21 °C	Comfort = <b>24 °C</b>
Standby = 19 °C	Standby = <b>22 °C</b>
Night = 17 °C	Night = <b>20 °C</b>
Frost protection = 7 °C	Frost protection = 7 °C

Setpoints	
Parameter	Setting
Reference value for calculating the setpoint adjustment*	5.0 - 40 °C in 0.5 degree steps, <b>21.0 °C = 21.00 °C</b>
*based on the "Current setpoint temperature input" object.	
Heating	
Comfort setpoint	5.0 - 40 °C in 0.5 degree steps, <b>21.0 °C = 21.00 °C</b>
Standby setpoint	5.0 - 40 °C in 0.5 degree steps, <b>19.0 °C = 19.00 °C</b>
Night setpoint	5.0 - 40 °C in 0.5 degree steps, <b>17.0 °C = 17.00 °C</b>
Frost protection setpoint	0 - 15 °C in 1.0 degree steps, <b>7.0 °C = 7.00 °C</b>
Cooling	
Comfort setpoint	5.0 - 40 °C in 0.5 degree steps, <b>24.0 °C = 24.00 °C</b>
Standby setpoint	5.0 - 40 °C in 0.5 degree steps, <b>26.0 °C = 26.00 °C</b>
Night setpoint	5.0 - 40 °C in 0.5 degree steps, <b>28.0 °C = 28.00 °C</b>
Heat protection setpoint	18 - 40 °C in 1.0 degree steps, <b>35.0 °C = 95.0 °F</b>

**Correct and send actual temperature**

The actual temperature is affected by the following:

- Actual temperature inside (measured by internal sensors)
- Actual temperature outside (measured by external temperature sensors)
- Combination of internal and external actual temperature

You can set the temperature difference (the last difference transmitted compared to the current actual temperature) at which the actual temperature is transmitted, and the interval at which it should automatically be transmitted (e.g. to visualisation software).

Here, you can also set a correction value for the temperature sensor installed in the room temperature control unit. This is useful if it is installed in an unsuitable place in the room where the temperature is different from other places in the room (e.g. due to a draught or heat sources nearby), for example. The following formula applies:

Actual temperature = measured temperature + correction value

If you also use an external temperature sensor, you can set the percentage proportion at which the external actual temperature should be included in the current actual temperature. The external value is received via the "Current actual temperature input" object, read off by the room temperature control unit and calculated according to the set weighting. The "Current actual temperature output" object is then overwritten with the calculated actual value.

You can set the system to monitor the actual external

temperature cyclically. If the controller does not receive any new values during this time, a read request is sent. If no new value is received in response to this, the actual external temperature is equalised with the actual internal temperature.

If you do not want the actual external temperature to be monitored, set this value to "0".

Actual temperature (resulting)	
Parameter	Setting
Correct internal actual temperature factor (-128 ... 127) * 0.1 K	-128 ... 127, <b>0</b>
Take actual external temperature partially into account	5 % to 100 %, <b>No</b>
Monitor actual external temperature every ... min (0-255)	0 ... 255, <b>60</b>
Send actual temperature at a deviation of ... K	No 0.1 to 2.0 K, <b>0.2 K</b>
Send actual temperature every ... min	No 3 to 60 min, <b>10 min</b>

### Set temperature drop detection

When temperature drop detection is switched on, the room temperature control unit checks whether the temperature has changed by the set temperature difference within three minutes. If this is the case, the system switches to frost/heat protection mode for a period that you can set. After this time has elapsed, the controller switches back to the operation mode that was set previously.

You can set which temperature value or sensor the temperature for the measurement is taken from.

When using an external sensor, the actual temperature consists of the temperature measured on the room temperature control unit and the external temperature, depending on the parameterised weighting (see "Correcting and sending the actual temperature").

Temperature jump	
Parameter	Setting
Temperature jump detection	<b>No</b> +/- 0.2 K / 3 min ... +/- 4.0 K / 3 min
Duration of frost/heat protection at temperature jump (10-60 min)	10 - 60 min, <b>20 min</b>
Frost protection when heating Heat protection when cooling	
Temperature measurement	Of actual internal temperature Of actual external temperature Of actual internal or external temperature <b>Of (resulting) internal temperature</b>

### Set closed-loop control for heating and additional level

This tab only appears if you set the "Heating" or "Heating and cooling" control type in the "Control general" tab. Here, you can set which heating control type should be activated. For PI controls, you can select between five standard system types, for which the recommended parameters have already been preconfigured. However, if you have sufficient specialised knowledge, you can also set the control parameters as required.

For 2-step control, set the hysteresis here.

Control heating	
Parameter	Setting
Basic level	
Direction of the controller	<b>Normal</b> Inverted
Correcting variable output	PI control (switching) <b>PI control (continuous)</b> 2-step control (switching) 2-step control (continuous)
Select heating system	Adjustment via control parameter <b>Warm water heating (5 K/ 150 min)</b> Underfloor heating (5 K/ 240 min) Electric heating (4 K/100 min) Air convector (4 K/90 min) Split unit (4 K/90 min)
Hysteresis	0.3 K - 2.0 K, <b>0.5 K</b>
Proportional range for heating in 0.1 K (10-255)	10 - 255, <b>40</b>
Reset time for heating (1-255 min)	<b>No</b> , 1 - 255

Here, specify the settings for the second heating level.

Control heating	
Parameter	Setting
Use additional level	Yes <b>No</b>
Direction of the controller	<b>Normal</b> Inverted
Correcting variable output	<b>2-step control (switching)</b> 2-step control (continuous)
Level interval factor (10 ... 100) * 0.1 K	10 ... 100, <b>20</b>
Hysteresis	0.3 K - 2.0 K, <b>0.5 K</b>

Getting to know and parameterising the room temperature control unit

**Set control cooling and additional level**

This tab only appears if you set the "cooling" or "heating and cooling" control type in the "Control general" tab. Here, you can set which cooling control type should be activated. For PI controls, you can select between three standard system types, for which the recommended parameters have already been preconfigured. However, if you have sufficient specialised knowledge, you can also set the control parameters as required.

For 2-step control, set the hysteresis here.

<b>Control cooling</b>	
Parameter	Setting
Basic level	
Direction of the controller	<b>Normal</b> Inverted
Correcting variable output	PI control (switching) <b>PI control (continuous)</b> 2-step control (switching) 2-step control (continuous)
Select cooling system	Adjustment via control parameter  Air convector (4 K/90 min) Split unit (4 K/90 min) <b>Cooling ceiling (5 K/240 min)</b>
Hysteresis	0.3 K - 2.0 K, <b>0.5 K</b>
Proportional range for cooling in 0.1 K (10-255)	10 - 255, <b>40</b>
Reset time for cooling (1-255 min)	<b>No</b> , 1 - 255

Here, specify the settings for the second cooling level.

<b>Control heating</b>	
Parameter	Setting
Use additional level	Yes <b>No</b>
Direction of the controller	<b>Normal</b> Inverted
Correcting variable output	<b>2-step control (switching)</b> 2-step control (continuous)
Level interval factor (10 ... 100) * 0.1 K	10 ... 100, <b>20</b>
Hysteresis	0.3 K - 2.0 K, <b>0.5 K</b>

**Set correcting variables and valve protection**

Note that you need to set different parameters for 2-step control than you do for a PI control.

For "Cycle time of switching correcting variable", set the duration for the PI control. The calculated control value is always transmitted at the start of a cycle time. If the valve drive has not received a value (e.g. during commissioning), the room could continuously heat up or cool down. To prevent this, set the "Cycle time for automatic sending of correcting variable". The correcting variable is transmitted again within the set time (as a precaution).

**i** The minimum correcting variable must always be smaller than the maximum correcting variable!

**Valve protection**

Valve protection prevents the valves on the heaters becoming stuck due to deposits in the heating water when the heating is switched off for a longer period of time (e.g. over the summer). When the valve protection is switched on, the valves are opened for a preset duration (100% on the controller output) after a preset number of days, and are then closed again (0% on the controller output).

The following settings apply for the "Heating" "Cooling" controller types:

<b>Correcting variables</b>	
Parameter	Setting
Basic level	
Select a minimum correcting variable that is smaller than the maximum correcting variable.	
Cycle time of switching correcting variable (2-60 min)	2-60, <b>15</b>
Range of minimum correcting variable from 0 % to ... %	0 % - 100 %, <b>30 %</b>
Minimum correcting variable (0 % - 100 %)	0 % - 100 %, <b>30 %</b>
Range of maximum correcting variable from 100 % to ... %	0 % - 100 %, <b>70 %</b>
Maximum correcting variable (100 % - 0%)	0 % - 100 %, <b>70 %</b>
Change for which correcting variable is sent	2 % - 10 %, <b>3 %</b>
Send correcting variable cyclically	<b>Yes</b> No
Cycle time for automatic sending of correcting variable in min (1-60)	1-60, <b>30</b>
Send inactive correcting variable cyclically	<b>Yes</b> No
Use valve protection	Yes <b>No</b>
Activate valve protection every ... days (1 - 30)	1-30, <b>15</b>
Approach end position for ... min (1-30)	1-30, <b>4</b>
Additional level	
Send correcting variable cyclically	<b>Yes</b> No
Cycle time for automatic sending of correcting variable in min (1-60)	1-60, <b>30</b>
Send inactive correcting variable cyclically	<b>Yes</b> No
Use valve protection	Yes <b>No</b>
Activate valve protection every ... days (1 - 30)	1-30, <b>15</b>
Approach end position for ... min (1-30)	1-30, <b>4</b>

## Control problems – what to do if

Problem	Possible solution
The controller switches constantly between heating and cooling.	Increase the insensitive zone between heating and cooling or increase the "Waiting time after switching-over".
The setpoint is only reached very slowly.	Decrease the proportional range, either by selecting a system type with a smaller proportional range in the system-specific selection "Adjustment of the controller to the heating/cooling system", by directly reducing the proportional range via control parameters in the adjustment, or by decreasing the integral time.
The room temperature exceeds the limits when changes are made to the setpoint.	Increase the proportional range, either by selecting a system type with a larger proportional range in the system-specific selection "Adjustment of the controller to the heating/cooling system", or by directly increasing the proportional range via control parameters in the adjustment, or by increasing the integral time.
It is always too hot or too cold in the room.	Compensate for the room temperature measurement by changing the "Compensation of the internal actual temperature" parameters accordingly.

## Communication objects

You can select the following communication objects:

Function	Object name	Type	Prio	Flags	Behaviour
Control	Current actual temperature output	2 byte	Low	CRT	Transmit/read out
Control	Current actual temperature input	2 byte	Low	WCT+	Transmit/receive
Control	Current setpoint temperature output	2 byte	Low	CRT	Transmit/read out
Control	Current setpoint temperature input	2 byte	Low	WC	Receive
Control	Operation mode input	1 byte	Low	WC	Receive
Control	Frost/heat protection input	1 bit	Low	WC	Receive
Control	Heating/cooling input	1 bit	Low	WCT+	Transmit/receive
Control	Heating/cooling output	1 bit	Low	CRT	Transmit/read out
Control	Comfort input	1 bit	Low	WC	Receive
Control	Comfort extension output	1 bit	Low	CRT	Transmit/read out
Control	Comfort extension input	1 bit	Low	WC	Receive
Control	Night reduction input	1 bit	Low	WC	Receive
Control	Setpoint adjustment output	2 byte	Low	CRT	Transmit/read out
Control	Setpoint adjustment input	2 byte	Low	WC	Receive
Control	Disable object for input	1 bit	Low	WC	Receive
Control	Status	1 byte	Low	CRT	Transmit/read out
Control	Status	2 byte	Low	CRT	Transmit/read out
Control	Status (comfort)	1 bit	Low	CRT	Transmit/read out

Function	Object name	Type	Prio	Flags	Behaviour
Control	Status (standby)	1 bit	Low	CRT	Transmit/read out
Control	Status (night operation)	1 bit	Low	CRT	Transmit/read out
Control	Status (frost/heat protection)	1 bit	Low	CRT	Transmit/read out
Control	Status (dewpoint)	1 bit	Low	CRT	Transmit/read out
Control	Status (heating/cooling)	1 bit	Low	CRT	Transmit/read out
Control	Status (controller inactive)	1 bit	Low	CRT	Transmit/read out
Control	Status (frost alarm)	1 bit	Low	CRT	Transmit/read out
Control	Heating status (basic level)	1 byte	Low	CRT	Transmit/read out
Control	Cooling status (basic level)	1 byte	Low	CRT	Transmit/read out
Control	Correcting variable heating (basic level)	1 bit	Low	CRT	Transmit/read out
Control	Correcting variable heating (basic level)	1 byte	Low	CRT	Transmit/read out
Control	Correcting variable heating (additional level)	1 bit	Low	CRT	Transmit/read out
Control	Correcting variable heating (additional level)	1 byte	Low	CRT	Transmit/read out
Control	Correcting variable cooling (basic level)	1 bit	Low	CRT	Transmit/read out
Control	Correcting variable cooling (basic level)	1 byte	Low	CRT	Transmit/read out
Control	Correcting variable cooling (additional level)	1 bit	Low	CRT	Transmit/read out
Control	Correcting variable cooling (additional level)	1 byte	Low	CRT	Transmit/read out
Control	Dew point alarm	1 bit	Low	WC	Receive

### **Behaviour on bus voltage recovery / bus voltage failure**

#### **Behaviour on application/recovery of the bus voltage**

Depending on the application settings:

- One of the following operation modes is activated: comfort, standby, night, frost/heat protection or the last operation mode.

Telegrams

- Telegrams for the control function (actual temperature, correcting variables etc.) may be transmitted.

#### **Behaviour when bus voltage fails**

- No

### **Merten GmbH**

Merten GmbH, Solutions for intelligent buildings, Service Center, Fritz-Kotz-Str. 8, Industriegebiet Bomig-West, D-51674 Wiehl

Phone: +49 2261 702-204

Fax: +49 2261 702-136

E-Mail: [servicecenter@merten.de](mailto:servicecenter@merten.de)

Internet: [www.merten.com](http://www.merten.com)

#### **If you have technical questions, please contact our InfoLine:**

Phone: +49 1805 212581\* or +49 800 63783640

Fax: +49 1805 212582\* or +49 800 63783630

E-Mail: [infoline@merten.de](mailto:infoline@merten.de)

\*fee required